

TFP260 Floor Planer

Operation and Maintenance Manual



DECLARATION OF CONFORMITY

We,

Trelawny SPT Limited of
Trelawny House, 13 Highdown Road, Sydenham Industrial Estate, Leamington Spa, Warwickshire, CV31
1XT, United Kingdom,

Declare that under our sole responsibility for supply/manufacture of the product

Name of product _____

Model, Serial Number _____

Year of production _____

to which this document relates is in conformity with the provisions of the following Directive(s), Normative Documents and their relevant Standards:

2006/42/EC	MACHINERY DIRECTIVE
2006/95/EC	LOW VOLTAGE DIRECTIVE (Applicable only to products using electric power)
EN ISO 11148-4:2012	HAND HELD NON-ELECTRIC (Non-Rotary Percussive Tools)

Date and place of issue,
24th June 2016
Leamington Spa, England.

CE



Rob Chapman,
Managing Director.

CZ	<p>Prohlášení o přizpůsobení My, společnost Trelawny SPT Limited podajemy daňové přiznání, že výrobek a dodávka výrobku název výrobku Model, výrobní číslo Rok výroby Pro které se průkaz týkající, je přizpůsobení s zásoby od následující příkazov a jejich pohotovosti: 98/37/EC Příkaz soustrojí 73/23/EC Příkaz nízkého napětí (upotřebitelné jediné do výrobku použití elektrické energie)</p>	LT	<p>ATITIKTIES DEKLARACIJA Mes, Trelawny SPT Limite Prisiimdami visą atsakomybę, deklaruojame, kad tiekiamas / gaminamas produktas Produkto pavadinimas Modelis, serijos numeris Pagaminimo Kuriam taikoma ši deklaracija, atitinka šių direktyvų, norminių aktų ir su jais susijusių standartų reikalavimus: 98/37/EC Įrangos direktyva 73/23/EC Žemos įtampos direktyva (taikoma tik elektriniams įrengimams)</p>
DE	<p>Übereinstimmungserklärung Wir, Trelawny SPT Limited erklären, dass unter unserer alleinigen Verantwortung für die Lieferung und Herstellung des Produktes Name des Produktes Model, Seriennummer Jahr der Herstellung auf welches sich dieses Dokument bezieht, stimmt mit den Vorgaben der folgenden Richtive, normativen Dokumente und deren jeweiligen Masstabe ein: 98/37/EC Maschinieredirektive 73/23/EC Niederspannungsrichtve (nur zutreffend auf Produkte, die Strom benutzen)</p>	MT	<p>DIJARAZZJONI TA KONFORMITA Ahna, Trelawny SPT Limited Niddikjaraw li ahna responsabbli kompletament għal provista / manfatura tal-prodott hawn imsemmi : Isem Il-Prodott Mudell, Serial number Sena ta 'produzzjoni Dan id-dokument magħmul għal prodott imsemmi hawn fuq, li huwa skond il-provizjonijiet imsemmija fid-dokumenti tal-klassi tax-xogħol : 98/37/EC Machinery Directive 73/23/EC Low Voltage Directive (tapplika biss għal prodotti li jaħdmu bl-elettriku)</p>
DK	<p>Erklæring om overensstemmelse Vi, Trelawny SPT Limited Erklærer hermed at under vores ene forhandling ansvar for vores forhandling/produktion af produktet Produkt navn Model, serie nummer Produktionsår For hvilket dette dokument referer, at det er i overensstemmelse med bestemmelser af følgende direktiver, normative dokumenter og deres relevante standart: 98/37/EC Machinery directive 73/23/EC Low voltage directive</p>	NL	<p>EENVORMIGHEIDSVERKLARING Wij, Trelawny SPT Limited Verklaan dat wij de volledige verantwoordelijkheid dragen voor het leveren/fabriceren van het volgende product: Naam van het product Type, Serienummer Productiejaar En verklaren dat het product waarnaar dit document verwijst eenvormig is met de voorzieningen van de volgende Richtlijn(en), Normatieve Documenten en hun relevante Standaarden: 98/37/CE MACHINERICHTLIJN 73/23/CE LAAGSPANNINGSRICHTLIJN (uitsluitend van toepassing bij producten die elektrische stroom gebruiken)</p>
EE	<p>TOOTE VASTAVUSE DEKLARATSIOON Meie, Trelawny SPT Limited Deklareerime, et vastutame järgmise varustuse/toote müügi eest Toote nimetus Mudel, Seeria number Aasta toodangu Antud dokument tõendab toote vastavust järgmistele direktiividele, normatiivkiitele ja nendega samaväärsetele standarditele: 98/37/EC MASINA DIREKTIIVID 73/23/EC MADALPINGE DIREKTIIVID (Kohandatakse vaid toodetele, mis kasutavad elektrivoolu)</p>	PL	<p>Deklaracja Zgodności My, Firma Trelawny SPT Limited, oświadczamy w naszej odpowiedzialności, że produkcja i dostawa urządzenia Nazwa produktu Model, numer seryjny Rok produkcji do którego ten dokument należy, jest zgodne z klauzulami następujących zarządzeń i ich istotnych standardów: 98/37/EC Zarządzenie mechaniczne 73/23/EC Zarządzenie niskiego napięcia elektrycznego (Zastosowanie tylko przy urządzeniach elektrycznych)</p>
ES	<p>Declaración de Conformidad Nosotros, Trelawny SPT Limited Declaramos que bajo nuestra completa responsabilidad de la fabricación/suministro del producto Nombre del Producto Modelo, No de Serie Año de producción A quién este documento se refiere, está de acuerdo con lo relacionado en la Directriz, Normativa Documentada y sus relevantes standards: 98/37/EC Directorio de Maquinaria 73/23/EC Directorio de Bajo Voltaje (Aplicable solamente a productos que funcionen con electricidad)</p>	PT	<p>DECLARAÇÃO DE CONFORMIDADE CE A empresa TRELAWNY SPT LIMITED Declara, sob sua inteira responsabilidade, que o fornecimento/fabrico do seguinte produto: Designação do produto Modelo, Número de Série Ano de produção a que esta declaração se refere, está em conformidade com o preceituado nas Directivas e Normas Comunitárias abaixo indicadas: 98/37/EC DIRECTIVA DE MÁQUINAS 73/23/EC DIRECTIVA DE BAIXA VOLTAGEM (Aplicável apenas a produtos que utilizam energia eléctrica)</p>
FI	<p>ILMOITUSVAHVISTUS Me, Trelawny SPT Limited Vahvistamme tuotteiden toimittamisesta/valmistamisesta Tuotenimi Malli, sarjanumero Valmistusvuosi Tallä todistuksella vahvistamme säädökset seuraviin ohje/ohjeisiin, Yleisiin papereihin ja niihin liittyvät vaatimukset: 98/37/EC KONEISTON OHJEET 73/23/EC PIENJÄNNITTE OHJEET (tarvitaan ainoastaan tuotteille jotka käyttävät sähkövoimaa)</p>	RU	<p>СВИДЕТЕЛЬСТВО О СООТВЕТСТВИИ Мы, Trelawny SPT Limited Заявляем, что несем полную ответственность за поставку/производство нижеуказанной продукции Наименование изделия Модель, серийный номер Год выпуска на которую выдано настоящее Свидетельство, и которая соответствует положениям следующей(их) Директив(ы), нормативным документам и относящимся к ним стандартам: 98/37/EC ДИРЕКТИВА ПО МЕХАНИЗМАМ 73/23/EC ДИРЕКТИВА ПО НИЗКОВОЛЬТНОМУ ОБОРУДОВАНИЮ (распространяется только на изделия с электропитанием)</p>
FR	<p>DÉCLARATION DE CONFORMITÉ Nous, soussignés Trelawny SPT Limited déclarons que le produit sous-nommé Nom du produit Modèle et Numéro de Série Année de production et pour lequel nous prenons entière responsabilité pour sa fourniture et manufacture, est conforme aux clauses des directives suivantes, documents normatifs et normes qui s'y appliquent: 98/37/EC DIRECTIVE POUR LA MACHINERIE 73/23/EC DIRECTIVE POUR BAS VOLTAGE (n'est applicable qu'aux produits utilisant l'énergie électrique)</p>	SE	<p>FÖRSÄKRAN OM ÖVERENSSTÄMMELSE VI, TRELAWNY SPT LIMITED FÖRKLARAR ATT VI MED ENSAMT ANSVAR ANSKAFFAT / TILLVERKAT PRODUKTEN PRODUKTNAMN MODELL och SERIE NUMMER Tillverkningsår TILL VILKEN DETTA DOKUMENT HÄNVISAR, ÄR I ÖVERENSSTÄMMELSE MED FÖLJANDE DIREKTIV, NORMATIVA DOKUMENT OCH DERAS RELEVANTA STANDARDER 98/37/EC MASKINDIREKTIV 73/23/EC LÅGSTRÖMSDIREKTIV (TILLÄMPLIG PÅ ELEKTRISK DRIVNA PRODUKTER)</p>
GR	<p>ΔΗΛΩΣΗ ΠΙΣΤΟΤΗΤΑΣ Η εταιρεία Trelawny SPT Limited Δηλώνει ότι έχει τη μοναδική ευθύνη ως κατασκευαστρια / προμηθευτρια του παρακάτω προϊόντος περιγραφή προϊόντος μοντέλο, αριθμός σειράς έτος παραγωγής και στο οποίο αναφέρεται αυτή η δήλωση, είναι συμβατό με τις προδιαγραφές που ορίζονται στις ακόλουθες Κοινοτικές Οδηγίες Ελεγκτικές Διατάξεις κι άλλες σχετικές προδιαγραφές 98/37/EC ΟΔΗΓΙΑ ΠΕΡΙ ΜΗΧΑΝΗΜΑΤΩΝ 73/23/EC ΟΔΗΓΙΑ ΠΕΡΙ ΧΑΜΗΛΗΣ ΤΑΣΗΣ (αφορά μονο προϊόντα που λειτουργούν με ηλεκτρικό ρεύμα)</p>	SI	<p>IZJAVA O SKLADNOSTI Trelawny SPT Limited pod polno odgovornostjo izjavljamo, da so spodaj navedeni proizvodi, ki jih dobavljamo/proizvajamo: Ime proizvoda Model, serijska številka Leto proizvodnje na katere se ta dokument nanaša, proizvedeni v skladu z določili naslednjih direktiv, normativnih dokumentov in njihovih relevantnih standardov: 98/37/EC DIREKTIVA O STROJIH 73/23/EC DIREKTIVA O STROJIH Z NIZKO VOLTAŽO (nanaša se samo na proizvode na električni pogon)</p>
HU	<p>MEGFELELŐSÉGI NYILATKOZAT Mi, A "Trelawny SPT Limited" cég Felelősségünk tudatában kijelentjük, hogy mint a termék szállítója/ gyártója Termék neve Típus, Sorozatszám Gyártási év amelyre jelen dokumentum vonatkozik, megfelel az alábbi Irányelv(ek), Irányadó Dokumentumok előírásainak, és az azokat meghatározó szabványoknak: 98/37/EC GÉPÉSZETI IRÁNYELVEK 73/23/EC KISFESZÜLTÉGŰ IRÁNYELVEK (Csak az elektromos meghajtású gépeknél)</p>	TR	<p>UYGUNLUK BEYANI Trelawny SPT Limited Aşağıdaki, üretim ve tedarikinden tek başına sorumlu olduđu ürünün Ürün adı Model/Seri no Üretim yılı bu belgenin ilgili olduđu aşağıdaki yönetmeliklerin, norm belgelerinin ve ilgili standartlarının kopullarına uygun olduđunu beyan eder: 98/37/EC MAKYNALAR YONETMELYDY 73/23/EC DÜPÜK GERÝLYM YONETMELYDY (Yalnızýz elektrikle çalypan ürünlerde geçerlidir)</p>
IT	<p>DICHIARAZIONE DI CONFORMITA La Società Trelawny SPT Limited Dichiara, sotto la propria responsabilità, che la fornitura / produzione del prodotto Nome prodotto Modello, codice Anno di produzione a cui si riferisce tale documento è conforme alle seguenti Direttive, ai documenti della Normativa ed ai relativi standard: 98/37/EC DIRETTIVA SULLE APPARECCHIATURE 73/23/EC DIRETTIVA SUL BASSO VOLTAGGIO (applicabile esclusivamente per i prodotti che utilizzano energia elettrica)</p>		

OPERATION

Foreword

Thank you for your purchase of the TRELAWNY TFP260 Floor Planer.

This manual contains the necessary maintenance information for you to ensure proper operation and care for this machine.

See also the manual that is supplied by the engine manufacturer.

It is essential for you to read through these manuals thoroughly.

In the unlikely event that you experience problems with your TFP260, please do not hesitate to contact your local Trelawny dealer or agent. We always welcome feedback and comments from our valued customers.

General Information

Before operating, performing maintenance or repairing the TFP260 FLOOR PLANNER this manual must be read and understood by the operator, if in any doubt, ask your supervisor before using this equipment.

Local safety regulations must be followed at all times. Failure to follow these instructions could result in damage to the TFP260 and/or personal injury.

Trelawny SPT Limited disclaims all responsibility for damage to persons or objects arising as a consequence of incorrect handling of the machine, failure to inspect the machine for damage or other faults that may influence the operation prior to starting work, or failure to follow the safety regulations listed or applicable to the job site.

This machine is primarily designed for the removal of paint, heavy rust, scale and for the removal of laitance from concrete from floor areas. It can be used both indoors and out. Electric models are more suitable for indoor use because of the toxic gases that are produced by petrol engines.

This machine must not be used in a fixture.

Safety

WEAR SAFETY BOOTS, FACE MASK, SHATTERPROOF GLASSES, HELMET, GLOVES and any other personal protective equipment required for the working conditions. Avoid loose clothing; this may become trapped in moving parts and cause serious injury.

TO AVOID NUISANCE DUST, connect an industrial vacuum cleaner (minimum 3000watts or equivalent) to the 50mm (2") vacuum port situated at the rear of the machine.

ENSURE THAT THE WORK PLACE IS WELL VENTILATED. Avoid operating engine-powered machines in an enclosed area, since engine exhaust gases are poisonous.

BE VERY CAREFUL WITH HOT COMPONENTS. Exhausts and other parts of the engine are hot during operation and can remain hot for some time after shutdown.

DO NOT REFUEL THE ENGINE WHILE THE ENGINE IS HOT OR RUNNING, there is a very real danger from explosion – always refuel when the engine is cold, and in the open air.

During transportation fasten fuel cap tightly and close fuel cock.

DO NOT OPERATE ELECTRIC VERSIONS IN WET CONDITIONS.

CAUTION THIS MACHINE IS HEAVY. It weighs around (Wt 122 kg (269 lbs)) dependent on power unit. Do not lift this machine manually.

IMPORTANT:

When fitted with the petrol engine, AVOID TIPPING THE TFP260 BACKWARDS, especially when hot; the engine oil can run past the piston and into the combustion chamber causing the piston to "hydraulic lock" when next attempting to start the engine.

Never attempt to forcibly turn the engine over if this has taken place, severe damage to the engine can be caused, resulting in a costly major strip down and possible injury to the operator.

To remove the oil from the cylinder, first remove the spark plug and place a lint free cloth over the plughole to capture the jettisoned oil. Turn the engine over with the ignition switch and fuel cock in the off position and expel as much of the oil as possible. Clean the spark plug to remove oil from the electrodes and replace. The plug may have to be removed and cleaned several times before the engine will start. Upon starting, the engine may produce smoke for a while from the exhaust, but this should soon clear.

Finally stop the engine and recheck the engine oil level. (Ensure that the engine is level prior to carrying out this check). If the engine oil level is low, refill with the recommended motor oil - see engine manufacturers operating instructions.

Risk of Hand-arm Vibration injury

These tools may cause Hand-arm Vibration Syndrome injury if their use is not adequately managed.

We advise you to carry out a risk assessment and to implement measures such as; limiting exposure time [i.e. actual trigger time, not total time at work], job rotation, ensuring the tools are used correctly, ensuring the tools are maintained according to our recommendations, and ensuring that the operators wear personal protective equipment [PPE] particularly gloves and clothing to keep them warm and dry.

Employers should consider setting up a programme of health surveillance to establish a benchmark for each operator and to detect early symptoms of vibration injury.

We are not aware of any PPE that provides protection against vibration injury by attenuating vibration emissions.

See 'Specifications' section for vibration emission data.

Further advice is available from our Technical Department.

We strongly advise you to visit the Health & Safety Executive website <http://www.hse.gov.uk/vibration> This site provides excellent advice and information on HAV and currently, includes a Hand-arm Vibration Exposure Calculator that is easy to use to work out the daily vibration exposure for each of your operators.

Cutter types & Applications

T.C.T

Hardened steel cutter with tungsten carbide inserts. For all general cleaning applications, including concrete texturing, Scabbling, the grooving of concrete, removal of embedded roof chippings, brittle coatings from steel work. Use TCT Cutters on heavy applications, for longer life and higher output. *Produces "tramlines" on concrete and small indentations on steelwork.*

STAR

Heat-treated steel cutters used for the aggressive removal of Paint and coatings from floor areas, but with a shorter life span than Beam Cutters. Can be used for the general removal of dirt and ice deposits and to produce a texture on concrete surfaces. *Produces roughened surface on concrete and some marking on steelwork.*

BEAM

Heat-treated steel cutters used for the removal of Paint and coatings from floor areas, but with a shorter life span than TCT Cutters, not as aggressive as Star Cutters. Can be used for the general removal of dirt and ice deposits. *Produces a fine texture on concrete surfaces and slight marking on steelwork.*

MILLING

Flat tungsten carbide cutters for the removal of thermo-plastic road and runway markings. Very efficient and cost effective with none of the problems associated with burning off. These can also be used for the removal of bituminous and rubber deposits. Very effective for the removal of two part epoxy floor paint, may require finishing with beam cutters or the Trelawny floor grinder to achieve the required finish.

Note: Care must be taken with milling cutters to ensure that the Drum and its Cutters are fitted the correct way round, the tungsten carbide tips must face towards the vacuum port at the bottom as the drum rotates, otherwise the tips will be damaged in use. *Produces a "strip" on concrete and tarmac, is not recommended on steelwork unless used for "braking up" coatings.*

NB: Increasing or decreasing the number of spacers used can alter the performance and finish characteristics of each cutter type. Ensure that the same type and quantity of spacers and cutters are fitted to the opposite cutter shaft to maintain the drums balance. An out of balance drum can be very dangerous and will also **dramatically increase the vibration emissions.**

OPERATION

Pre-Start Check

Check all bolts and screws for tightness. Ensure that all fittings are secure.

Check the drive belt for correct tightness. There should normally be approximately 13mm (1/2") of free play when one side of the belt is depressed in the middle position between the two pulleys. To set the belt tension, refer to the *Belt installation & Setting* section.

For Petrol Engines

Check engine oil level. If the engine oil level is low, refill with the relevant motor oil recommended in the engine manufacturers operating and maintenance manual.

IMPORTANT: Do not lean the machine backwards onto its handle to inspect the cutters or drum. It is possible for engine oil to seep into the cylinder bore, especially if the engine is hot. If this has occurred,

DO NOT ATTEMPT TO START THE ENGINE,

the oil can cause the piston to lock hydraulically, which may cause severe damage to the engine and injure the operator. With ignition turned off, very slowly pull the starter cord, if the engine cannot be turned over, the above may have taken place.

Rectification will necessitate the spark plug being removed and the engine turned over by pulling the starter cord (with ignition turned off) to "eject" the oil. Use a lint free clean cloth over the plughole to capture the ejected oil. The spark plug will require removing and cleaning, possibly several times until the engine restarts.

415v Motors

The TFP260 is supplied with a specially commissioned electric motor and starter switch assembly. Each unit is fully tested and the overload relays have been calibrated and set according to the manufactures specifications. In the event of malfunction on a new machine, the owner should first check that the power supply on site is suitable and adequate. All cables should be fully uncoiled and never left wrapped around cable reels or tied in loops. The starter box is fitted with a safety feature to protect the motor and relays from damage.

The starter boxes are preset and under no circumstances should they be tampered with, stripped down or adjusted, otherwise it will invalidate the warranty.

Take particular care when using 415v Machines; ensure that the electrical supply is earthed and that breakers and fuses are correct for the loading. The switches are preset and under no circumstances should they be tampered with, stripped down or adjusted, otherwise it will invalidate the warranty.

The 415v motor requires the minimum of a 10amp, 380v power supply

Always use the shortest possible length of extension cable. To avoid voltage drop the cable must have a minimum core wire size of 2.5mm² cross-section area.

Maximum length of cable 30 meters.

Starting

Engine models:

Check that there is sufficient fuel in the fuel tank. (See manufactures hand book for type) Check that the engine oil level is correct. (See pre-start check). Ensure that the machine cutting depth adjustment hand wheel (55) is in the fully raised position. (Cut engagement lever (58) must be in the down/forward position to make any adjustment) Depress the hand wheel (55) to disengage the locking pin and rotate anti clockwise until the cut engagement (58) lever is nearly vertical.

IMPORTANT

Do not pull the recoil starter cord to the end of its travel as it may cause damage to the engine or injury to the operator.

When the engine starts, recoil the cord slowly.

Do not allow the cord to snap back to its start position.

Open the engine fuel cock.

Set the throttle lever on the engine to approximately a halfway open position.

For cold engine starting, move the carburettor choke lever to the choke "full on" position.

Set the engine switch to the "on" position.

Where fitted, pull the Hold to run lever towards the handle bar.

Pull the recoil starter cord handle.

After the engine starts, open the choke approximately halfway, or until the engine runs smoothly. Warm the engine up for 2~3 minutes at half engine speed before opening the choke fully.

The warm up procedure is particularly important during cold weather.

Electric models: Follow instructions in Starting at paragraph three, then pull the Hold to run lever towards the handle bar, press start button on control box. Continue instructions with item 2,3 and 4 in Machine Operation below.

Machine Operation

Ensure that the depth of cut adjustment hand wheel is in the fully raised position and the cut engagement lever is up.

On Petrol engines set the throttle lever on the engine to fully "open/run" position.

Continue holding the handle bar and dead mans handle in the "on" position.

Place the cut engagement lever in the forward engaged position and slowly rotating clockwise the depth of cut hand wheel (55).

The cut engagement lever (58) will move forward/down while adjustment is made, if it does not, ensure that the cut engagement lever has been pushed to the forward position.

Adjust the depth of cut hand wheel until the cutters are in contact with the surface, slowly adding more cut until sufficient material is being removed. Be aware that several lighter cuts is more efficient than one heavy cut. Heavy cuts will only increase wear of drum components and increase operator fatigue.

The Planer may move forward during the cutting operation, due to the action of the cutter drum. Control this by holding the handle bar. When working on rough surfaces the machine may jerk forwards if too heavy a cut is made. Reduce the amount of cut by raising the cutters via the cutting depth adjustment hand wheel (55).

When the end of the run has been completed, end the cut by raising the cutter engagement/ disengagement lever (58).

Position the machine for the next run, and then slowly lower the cutter engagement lever again.

ENGINE VERSIONS CAUTION

Beware of **POISONOUS FUMES**. Start and operate only in well-ventilated areas.

Be careful with **HOT COMPONENTS**.

Exhausts and other engine parts are hot during and for some time after operation.

Do not touch them.

Shut Down

All Versions

Raise the cutters using the drum cutting depth adjustment hand wheel (55).

Lift the cutter engagement / disengagement (58) lever to the raised position.

Electric version only, now release the hold to run lever, the electric motor will then stop.

Petrol Engine Versions

Move the engine's throttle lever to the slow speed position and run the engine for 20 seconds, (This avoids the engine bore from becoming washed internally by neat fuel.)

Where fitted, release the hold to run lever on the machines handle bar, the engine will now stop.

Switch off the engine's ignition switch.

Close the engine fuel cock.

: EMERGENCY SHUTDOWN :

Where fitted, Release Hold to run lever on the handle bar or switch off the ignition switch on the engine.

Machine Storage

Short period storage: up to 3months.

Clean outside of machine, remove drum and inspect for wear, replace any worn parts as required.

Remove any build up of material from inside of drum housing area; spray drum with a light coating of suitable anti rust agent.

See also *engine manufactures operation and maintenance instruction book*.

Cover the machine to protect it: Store the Planer in a dry place.

Long period storage: over 3months

Clean outside of machine, remove drum and inspect for wear, replace any worn parts as required.

Remove any build up of material from inside of drum housing area; spray drum with a light coating of suitable anti rust agent.

When engine is cold, remove the fuel from the fuel tank and carburettor float chamber; see engine manufactures operation and maintenance instruction book for method.

Electric Motors only, protect plug and motor against corrosion and moisture.

Cover the machine to protect it: Store the Planer in a dry place.

SERVICING

Belt Removal & Installation

Remove the belt Guard by unscrewing the 8mm and 10mm securing bolts. Slacken off the engine/motor mounting plate bolts and loosen both belt adjusting bolts locking nuts. Unscrew the adjuster bolts (39) to loosen the drive belt, and then slide the toothed belt (34) off the drive pulley (28).

Fit a new belt onto the pulleys as described above.

Adjust the belt tension using the belt adjusting bolts (39) and then tighten the locknut against the engine mounting plate, ensure the belt tension is correct. (Do not over tighten)

Tighten all engine mounting plate bolts and locknuts.

Refit the belt guard (36) and tighten the retaining bolts.

IMPORTANT

Normal slack should be approximately 13mm (1/2") when the belts are depressed in the middle position between the engine/motor pulley and drum pulley.

Greasing points

There are three greasing points (67) on this machine, two at the lift lever and one on the Side Plate Bearing Housing (16) at the front of the machine. The latter provides lubrication and protection to the drive shaft/side plate bearing spigot which could seize together if used in damp conditions and then left. Lubricate these regularly if in constant use.

There is no lubrication required for the Drive side bearings, these are sealed for life.

Grease the screw thread of the Lift Rod Shaft(20) occasionally to ensure smooth action of lift mechanism.

MAIN ASSEMBLY

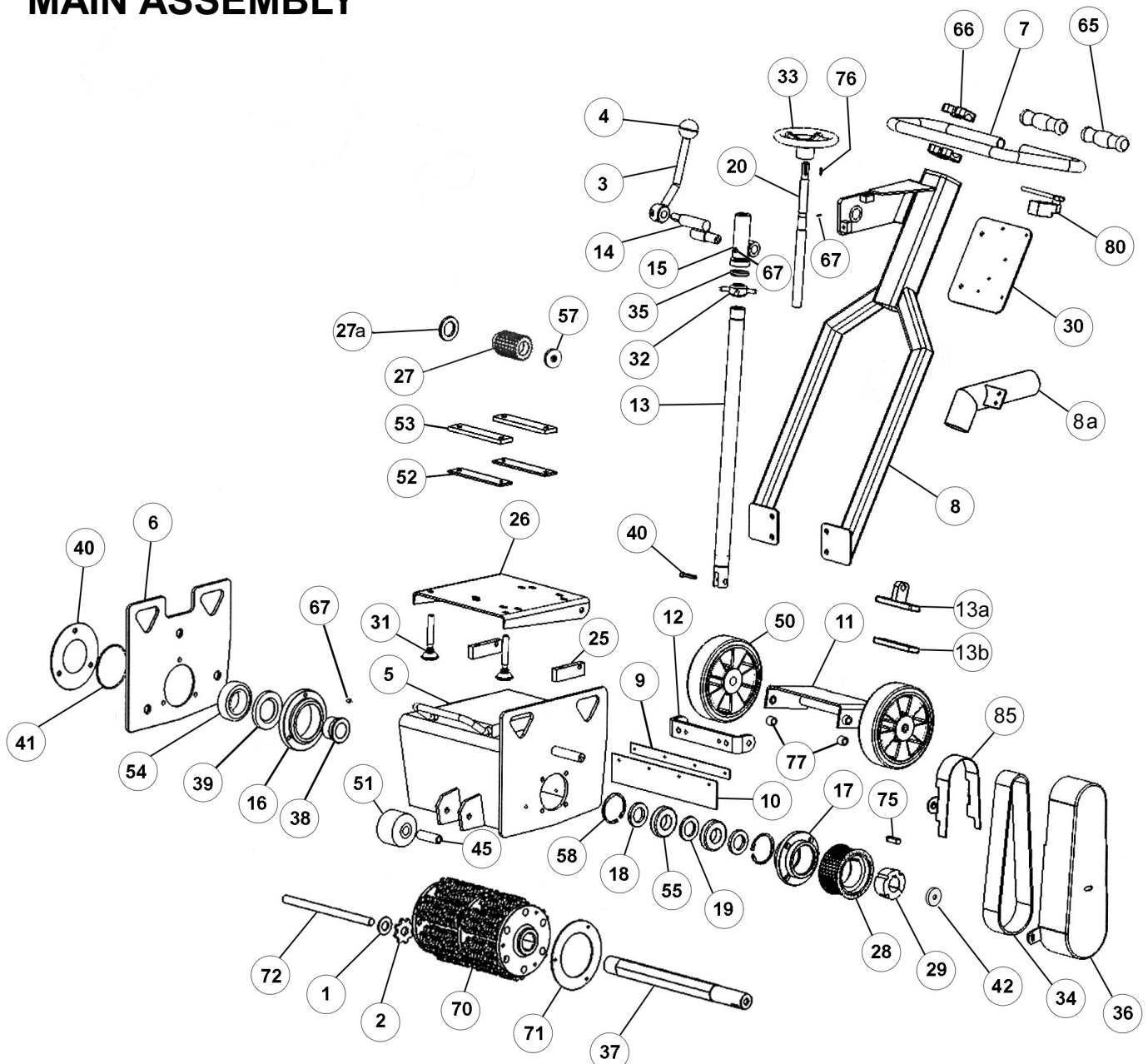

Item	Part Number	Description	Item	Part Number	Description
1	320.7009	TCT Cutters (123 req)	39	326.9115SR	Grease Seal
	326.3658	Star Cutters (Not Shown) (342 req)	40	326.9101AR	Side Plate Cover
	326.5120	Beam Cutters (Not Shown) (332 req)	41	809.6115	O'Ring Seal
	320.5680	Milling Cutters (Not shown) (60 req)	42	326.9128R	Pulley Retaining Washer
2	320.4160	Spacers (154req)	45	326.9150	Front Wheel Spacer
3	325.9131	Lift Lever	50	350.9121	Rear Wheel 150mm dia
4	325.9170	Lift Lever Ball Knob	51	326.9161	Front Wheel 82mm dia
5	326.9100	Cutter Drum Box (includes Side Plate)	52	326.9163	Electric Motor Clamping Plate
6		See item 5	53	326.9164	Electric Motor Mounting Plate
7	326.9103	Handle Bar	54	326.9165R	Large R/Bearing (Side Plate Side)
8	326.9105	Handle Assembly	55	326.9166	Small Bearing x 2 (Drive Side)
8a	326.9175	Vacuum Take-off	57	326.9168	Electric Pulley Retaining Washer
9	326.9106	Dust Skirt Retainer		325.9167	Engine Pulley Retaining Washer
10	326.9107	Dust Skirt	58	814.3205	Circlip x 2 (Drive Side Bearing)
11	326.9110	Swing Arm			
12	326.9111	Axle Mounting Bracket			
13	326.9112	Lift Rod Assembly			
13a	326.9100L	Lower Lift Rod Mounting Bracket	65	822.2000	Rubber Grip
13b	326.9110M	Lower Lift Rod Mounting Threaded	66	835.9120	Alloy Clamp
14	326.9113	Lever Quadrant	67	858.1006	Grease Nipple (3 x required)
15	326.9114	Lift Nut	70	326.06DW	Double Web Drum
16	326.9115R	Side Plate Bearing Housing		326.060G	Grooving drum
17	326.9116	Drive Side Bearing Housing		326.1016DB	Drum Complete D/Web Beam
18	326.9117	Outer Bearing Spacer (2 x required)		326.1016DM	Drum Complete D/Web Milling
19	326.9118	Inner Bearing Spacer		326.1016GT	Grooving Drum Complete TCT
20	326.9119	Lift Rod Shaft		326.1016SB	Drum Complete S/Web Beam
25	326.9121	Block (Engine/Motor Mounting Plate)		326.1016ST	Drum D/Web TCT
26	326.9125	Engine/Motor Mounting Plate	71	326.00EP	End Plate (2 x required)
27	326.9126A	Electric Motor Pulley	72	326.0016	6 x Cutter Shaft
	326.9126	Petrol Engine Pulley			
27a	326.9127	Petrol Engine Pulley Spacer	75	855.1006	Drive shaft Key 10x8x30
28	326.9128	Drive Pulley	76	855.4414	Hand Wheel Key
29	326.9129	Taper Lock Bush	77	326.9109	Axle Spacer
30	326.9130	Starter Box Mounting Plate	80	320.9828	Deadmans Complete Switch Assembly
31	326.9143	Belt Adjuster Screw (2 x required)		320.9826	Deadmans Upper Switch (inc lever)
32	326.9135	Locking Wheel		345.9800	Deadmans Switch Box (No lever)
33	326.9136	Hand Wheel			
34	326.9137	Drive Belt (Electric)			
	326.9137A	Drive Belt (Petrol)			
35	326.9138	Thrust Bearing	85	326.9134	Rear Guard (Petrol engine only)
36	326.9139	Belt Guard			
37	326.9140R	Drive Shaft			
38	326.9140AR	Drive Shaft Bush			
			Not shown in exploded diagram		
				325.9141	8hp Honda Engine
				853.1725	Engine Pulley Retaining Countersunk Screw
				325.9185	415v 3ph 50/60hz Electric Motor
				325.9186	415v 11amp Starter Box

STARTER BOX COMPONENTS AND WIRING DIAGRAM

Trelawny
325.9186
415v 11amp

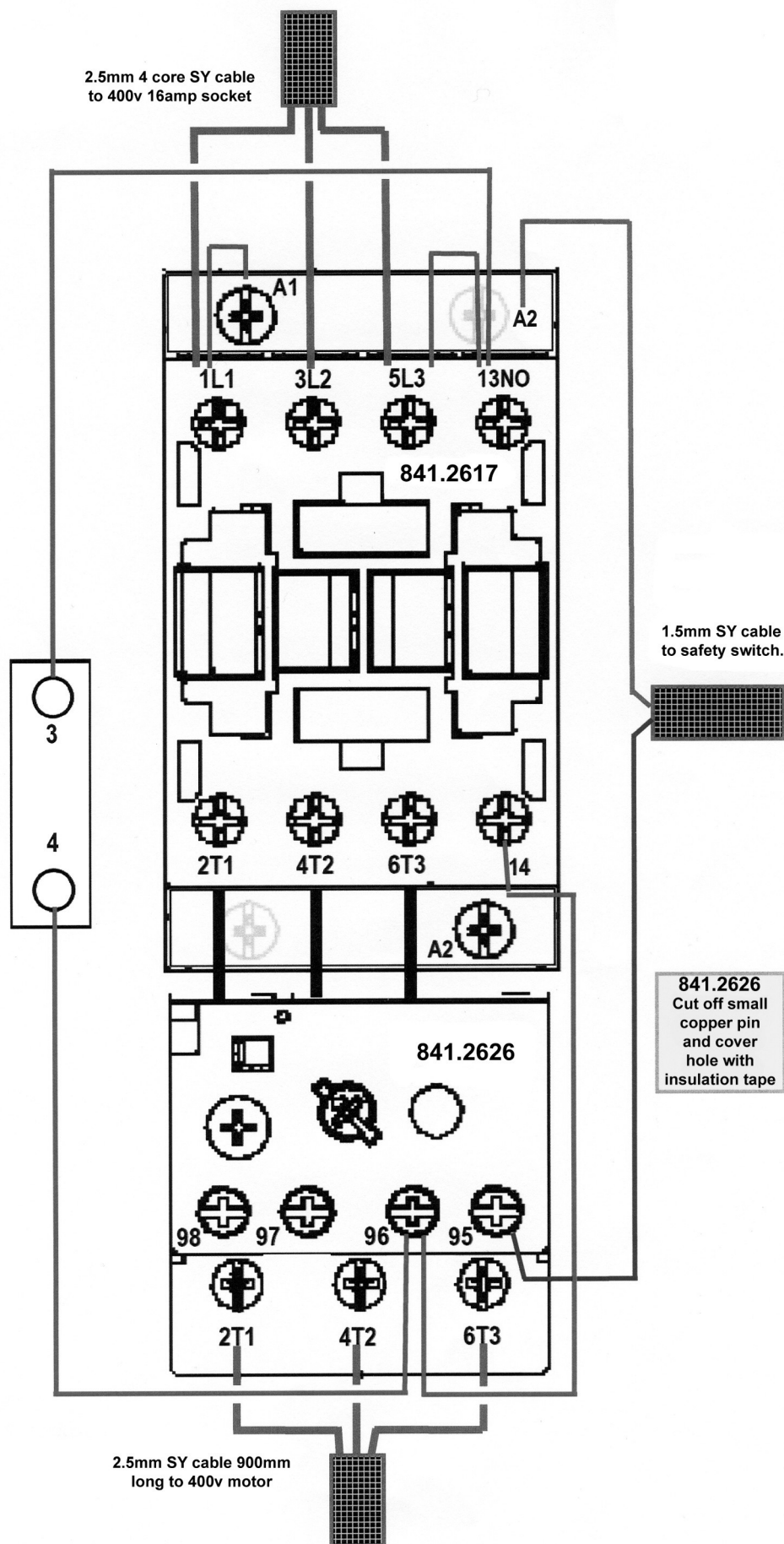

TECHNICAL SPECIFICATIONS

Technical Specifications

Height	1080mm	42.5"
Width	480mm	19"
Length	1010mm	40"
Cutting width	240 mm	9.4 inch
Average depth of cut (concrete with no aggregate)	6mm	0.25 inch
Drum rpm approximately	1850 rpm petrol, 1750 rpm electric	
Working distance from wall	75mm	3.0"
Weight	140 kg	308.5lbs
Power unit	8 hp Honda	5.96 kilowatt
Approximate Fuel Consumption	2.0 litre per hour	0.43 Gallon per hour
Power unit	7.5 hp Electric	415v 3ph 5.5kw
Noise L _{WA} - Declared noise emissions in accordance with BS ISO03744:2010 And BS EN ISO 15744:2008		
		102.5dB (A)
Vibration (AEQ) - at the handle bar	Petrol engine version	8.8 m/s ² (K= +40% -0%)
	Electric motor version	2.4 m/s ² (K= +40% -0%)

(k) ** Equals the factor of uncertainty, which allows for variations in measurement and production. Vibration Data figures are tri-axial, which gives the total vibration emission. Because of various factors, the range of vibration emission during intended use can vary.

The vibration is dependent on the task, the operators grip, and feed force employed etc.

NOTE: The above vibration levels were obtained from tri-axial measurements to comply with the requirements of "The Control of Vibration at Work Regulations 2005*" and the revisions to the (8662) now EN ISO 28927:2012 and EN ISO 20643:2005 series of standards. These values are at least 1.4 times larger than the values obtained from single axis measurements.

Based on European Union Council Directive 2002/44/EC (Physical Agents (Vibration) Directive)

This tool has been designed and produced in accordance with the following directive:

2006/42/EC

Machinery Directive

If your company has any problem with our products or would like to discuss the possibility of an improvement being made to them, then please do not hesitate to contact us.
Your comments are both important and appreciated.

Trouble Shooting

FAULT	CAUSE	ACTION
Engine stops suddenly or does not run correctly	No fuel in the fuel tank.	Refuel fuel tank. (See safety section.)
	Spark plug faulty.	Replace spark plug.
	Fuel blockage.	Check fuel line and strainer.
	Air cleaner blocked.	Replace air cleaner element.
	Low oil level.	Rectify leaks and replenish oil.
Electric motor stops suddenly	Blown electrical supply fuse.	Replace fuse.
	Motor overload protection activated	Disconnect electricity supply at mains and reset button inside starter box.
Electric motor will not start	Deadmans handle not engaged	Pull Deadmans level against handle bar and press start button.
Planer is slow or erratic	Drive Belt slack or failed teeth.	Replace Belts or adjust tension.
	Worn Drum Cutters	Replace Cutters.
	Surface too rough.	Use Trelawny TFP380 Planer to increase production.
Engine will not start	No fuel in the fuel tank.	Refuel fuel tank, see safety precautions.
	Low oil level.	Rectify leaks, replenish oil.
	Water in fuel.	Drain fuel tank, float chamber, and refuel.
	Spark plug faulty.	Replace spark plug.
Engine will not turn over	Oil in Cylinder.	See page 2 - section. Safety.
Use above information in conjunction with the engine manufacturers Operation and Maintenance Manual.		
If problem has not been cured by above actions, contact your local Trelawny agent or the engine manufacturer for advice or rectification.		

All rights reserved. Any unauthorised use or copying of the contents or part thereof is prohibited.

This applies to trademarks, model denominations, part numbers and drawings.

Use only genuine Trelawny spares.

The use of non-Trelawny spare parts invalidates the warranty.

Trelawny SPT Ltd
13 Highdown Road, Sydenham Industrial Estate, Leamington Spa,
Warwickshire, CV31 1XT, United Kingdom
Telephone: +44 (0)1926 883781 - Fax: +44 (0)1926 450352
Email: sales@trelawny.co.uk

© TSPT UK 2011 Part No: 735.5255 issue 5.4.17 (from serial number T40015)



www.trelawnyspt.co.uk