

Generation D

ANYmal X Technical Specifications

- Leading Autonomy & Mobility
- Intelligent Inspection
- Explosion-Proof Design



ANYbotics



Leading Autonomy & Mobility

Fully autonomous navigation and AI-based mobility enable ANYmal X to seamlessly conduct mission-critical inspections in multi-story and complex facilities with ease.

Intelligent Inspection

Utilizing high-resolution sensors and cutting-edge machine learning, ANYmal X delivers accurate real-time data, uploaded directly to customer systems via the ANYmal API.

Explosion-Proof Design

ANYmal X is the world's only Ex-certified legged inspection robot, designed to meet the challenges of deployment in hazardous and potentially explosive environments (Zone 1).

Ex-Proof Operations

ANYmal X provides autonomous robotic inspections in Oil & Gas and Chemicals facilities. The robot is certified for operation in Zone 1 according to the IECEx and ATEX standards. The system is also fully IP67 ingress protected and ready for long-term deployment in harsh outdoor environments.



ENVIRONMENTAL CONDITIONS

IECEx COMPLIANT

Ex db eb ib op is pxb sb IIB T4 Gb



ATEX COMPLIANT

Ex II 2G IIB T4



TEMPERATURE

Certified for operation between
0–40°C (32–104°F)

EXPLOSIVE GASES

Acetone, Ammonia, Butane,
Cyclohexane, Propane,
Methane, Toluene, Xylene,
Ethylene, Ethanol, MEK, etc.

INGRESS PROTECTION

IP67, fully protected against
water and dust and able to
operate in wet, humid, or dusty
environments.

PROTECTION METHOD

A pressurized main body filled
with inert Nitrogen gas and
revolutionary actuator design
enable ex-proof operations.

Extreme Mobility

ANYmal X's legged design and AI-based mobility software provide unprecedented mobility and performance. Combined with its obstacle avoidance capabilities, the robot is ready for use in complex and dynamic environments. The robot reliably navigates any environment and traverses rough terrain with ease. ANYmal X completes even challenging missions requiring it to climb steep stairs, pass through narrow corridors, or conquer rocky, slippery, or wet surfaces.



STAIRS

ANYmal X is capable of climbing and descending a variety of industrial stair types:

- Up to 45°
- Max rise 230 mm
- Min run 210 mm
- Min width 800 mm
- Open risers
- Grated steps



MOBILITY HIGHLIGHTS

STEP

250 mm



WALKING SPEED

Up to 1.0 m/s, recommended 0.5 m/s for increased efficiency and safety.



NARROW SPACE

600 mm



SLOPE

±30°



ACCURATE POSITIONING

Knows its absolute location with centimeter accuracy.



GAP

300 mm



SUSPENDED

600 mm

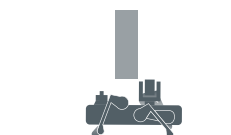

OMNIDIRECTIONAL

Steps sideways and turns in place.

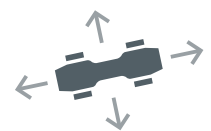

Full Autonomy

ANYmal X's unparalleled ability to perceive and navigate its environment powers fully autonomous operation. Once it maps an environment, the robot remembers every detail and can dynamically plan the best route to perform its mission, even without an internet connection. The robot can avoid collisions, plan & re-plan paths, and recharge autonomously in a safe zone. All this together enables safe, efficient, and continuous autonomous operation.

ROBOT DEPLOYMENT

SHOW & GO

Show the robot the environment and tasks by manually guiding the robot through the plant and indicating the location of inspection points. Set up missions that the robot will remember and autonomously repeat.

IMPORT CAD / BIM

Import your existing CAD models to virtually set up inspection points, paths, and missions. Perform realistic simulations of your inspection missions and software integration before the robot arrives at your facility to save on deployment time.



NAVIGATION WAYPOINTS

ANYmal X uses the points for autonomous navigation. It follows the shortest path between waypoints to target 3D coordinates throughout its inspection missions.

During deployment navigation waypoints are generated for planning robot missions. Points can later be added, edited, or removed in the Operator GUI.



INSPECTION POINTS & MISSION SETUP

Inspection points are defined as a special navigation goal for the robot in the user interface.

Inspection missions can be set up using the Mission Editor in the Operator GUI. Rule-based logic can be implemented to have the robot react to anomalies and alter its mission in real-time.



COLLISION AVOIDANCE MODES

The robot employs multiple modes to avoid collisions and safely stop near cliffs.

In *Stop & Go* the robot will stop before obstacles to avoid collisions and move again once the obstacle has moved.

In *Obstacle Avoidance* mode, if space is available, the robot will reroute around them. Alternatively, if a path is completely blocked, the robot can attempt to intelligently replan its route in order to complete its mission.



AUTOMATED SAFE ZONE CHARGING

The docking station enables continuous autonomous operation and is also defined as a point of interest during setup of the facility environment.

Missions can be set to any length as the robot will automatically navigate to the docking station when the battery is low and resume its mission after charging.

More information about the docking station and charger is available on page 9.

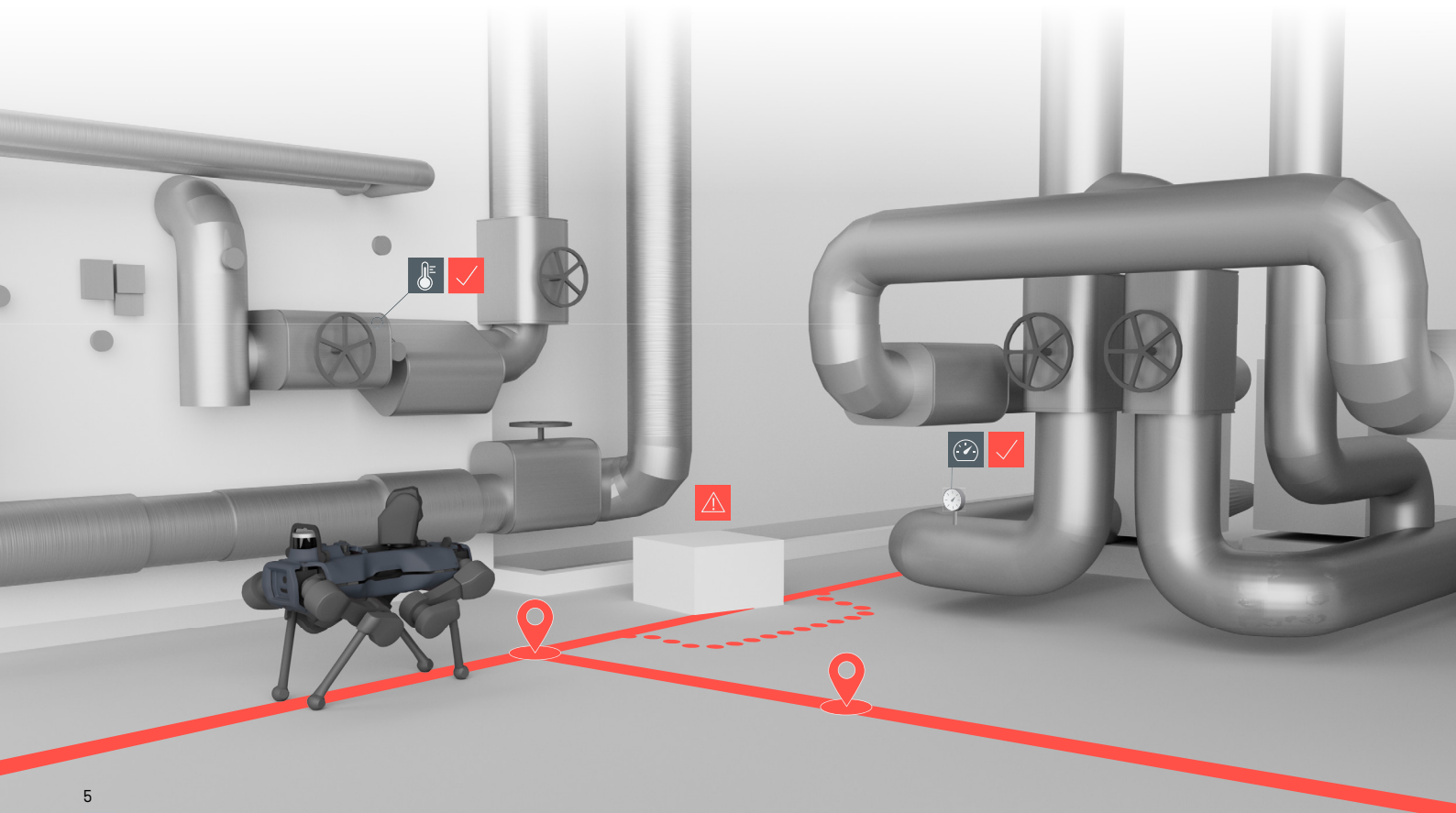

Industrial Inspection

READING INSTRUMENTS

A broad range of analog instruments and indicators can be digitized. Once trained on a type of instrument, the value or state is reliably identified.

Example: Pressure value, success status, confidence level and image of an analog gauge are recorded on the robot and transmitted to your data portal.



DETECTING EVENTS

Unforeseen technical events can result in hazardous situations. Equipped with precision sensors, ANYmal X detects dangerous conditions in the environment and triggers a warning when required.

Example: The temperature of the hottest point in the thermal image of a motor together with the image are reported to the plant operator.

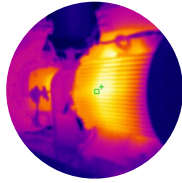

CHECKING HEALTH OF EQUIPMENT

Early signs of operating problems are caught by examining the general health of the equipment. During the inspection, ANYmal X checks critical points for anomalies and reports severe problems immediately.

Example: Sound recording and frequency analysis to detect unusual vibrations is performed by ANYmal X.



3D ENVIRONMENT SCANNING

Industrial environments require continuous tracking of structural changes. ANYmal X supports operations by scanning and documenting 3d environmental data.

Example: Dense point clouds are recorded with the LiDAR and depth cameras of ANYmal X and fused into a global point cloud map.

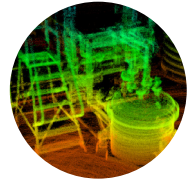

INSPECTION PIPELINE

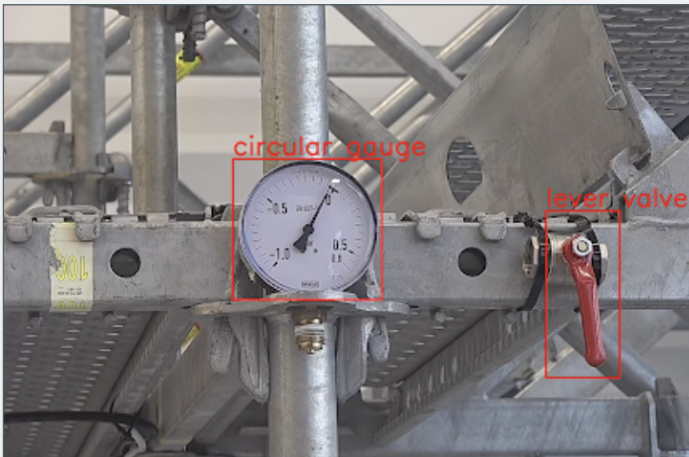

Detect and recognize objects, even if it has moved

Extract and process data

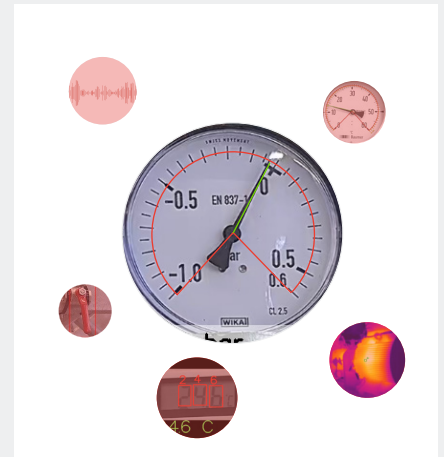

Collect multiple types of data for analysis and reporting

01



APPEND METADATA

Inspection results include pre-defined metadata fields such as time or location to add context to the data. The spatial metadata of each inspection point in your facility is recorded to ensure repeat inspection and support digital twins.

02



RULE-BASED LOGIC

Inspection missions can be programmed to change if certain inspection results are observed [e.g., a high or low threshold], enabling operators to prioritize inspection activities based on measured conditions on-site.

03



ASSOCIATE INSPECTION RESULTS

Multiple inspection results can be associated with each other to add additional context to the raw inspection data.

04



INSPECTION REPORTING

Generate reports of inspection results, export results to data portals or digital twin, or see inspection results live in the GUI when connected to the robot via Wi-Fi or LTE.

INSPECTION PAYLOAD

Zoom camera Default: 1080 × 1920 px (FullHD), 15 FPS
Maximum: 2160 × 3840 px (QFHD/4k), 30 FPS
20× optical zoom, 70.2° to 4.1° FOV (horizontal)

Thermal camera -10° to +400 °C (radiometry)
160 × 120 px
57° FOV (horizontal)

Microphone 3.75–20 kHz sampling frequency

Spotlight 947 lm continuous

Range of motion Pan: ±165°, tilt: -90°/+90°
Speed: 340°/s

Dimensions 219 × 177 × 246 mm (L/W/H) (with protectors)
(8.62 × 6.97 × 9.69 in)

Weight 6 kg (13.2 lbs)



GAS SENSOR PAYLOAD (OPTIONAL)

Compatible models Honeywell SensePoint
Drager PIR 3000

Payload Max. 2 sensors

Gas detection LEL: CH₄, C₂H₄, C₃H₈
PPM: O₂, CO, H₂S, Cl, SO₂, NO₂, NH₃

Electrical interface RS485 or 4–20 mA



ANYmal X

Dimensions	Length: 891 (35.06 in) Width: 651 mm (25.63 in) (default walking) Height: 872 mm (34.31 in) (default walking) / 440 mm (17.33 in) (lying on ground)
Weight	60.1 kg (132.5 lbs) with Inspection Payload and Gas Sensor
Walking speed	1.0 m/s maximum, rough or slippery terrain may reduce the walking speed, 0.5 m/s recommended for safe and efficient operation

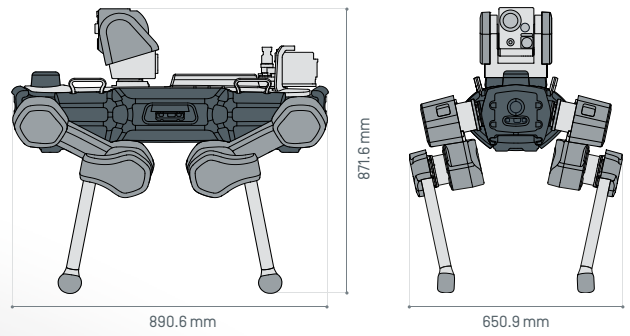

Edge Computing

Computers	2x 8th Gen Intel Core™ i7 (6-core) CPU with 2x 8 GB Memory (RAM)
Hard disks	2x 240 GB SSD
Operating system	Ubuntu 20.04

Telecommunication

Wi-Fi	Built-in module 2.4 / 5 GHz, 802.11ac wave2 Access point or client mode
4G LTE	Onboard module, LTE Cat.12

Battery

Battery & capacity	Swappable Li-ion battery, UN 38.3 certified 932.4 Wh
Running time & range	60—120 minute on a full charge 2.5 km range on a full charge, up to 1.5 km for a typical inspection mission depending on number of inspection points
Recharge time	3 h for full charge, 100 min for 70% quick charge
Dimensions	466 × 136 × 78 mm (18.35 × 5.35 × 3.07 in) [L/W/H]
Weight	5.5 kg (12.13 lbs)
Ingress protection	IP67

Perception Sensors

LIDAR	16 channels, 300'000 points/s, full sweep at 10 Hz 0.4—100 m range, 3 cm accuracy (typical) 360 × 15.0 to -15.0° FOV (Horizontal × Vertical) 905 nm, Class 1 Eye-safe per IEC 60825-1:2007 & 2014
Depth camera	0.3—3 m range, 87.3 × 58.1 × 95.3° depth FOV (Horizontal/ Vertical/ Diagonal), Class 1 Laser Product under the EN/IEC 60825-1, Edition 3 [2014]
Tele-operation cameras	1440 × 1080 px 110 × 76.5 × 117.7° FOV (Horizontal/ Vertical/ Diagonal)

Environmental conditions

Temperature	Specified: 0—40°C (32—104°F)
Day & night	No light required for autonomous operation and inspection. Low light (min. 20 lux) needed for automatic docking and tele-operation.
Water & dust ingress protection	Fully protected against water and dust (IP67) and able to operate in humid and dusty conditions.
Industrial floor	ANYmal X walks on metal, concrete, gratings / checkerboards, gravel, dirty, wet and slippery floors.

Perception Sensors Field of View

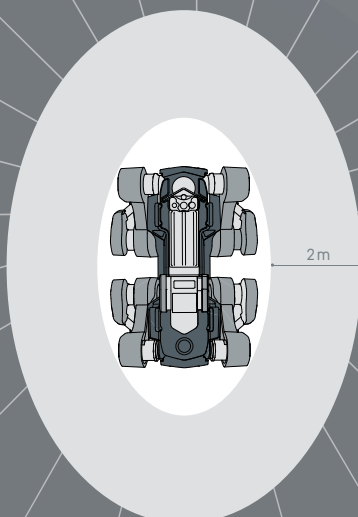

Dynamic sensing

High density near field sensing

Nearby the robot, the depth cameras detect details about the environment and obstacles within 2 m.

Accurate long range sensing

The powerful onboard Lidar is used for mapping, localization, and collision avoidance up to 100 m.

Automated End-to-End Workflow

Pre-scheduled or upon your operator's request, ANYmal X performs automated inspection routines with improved reliability and accuracy. The robot and its results integrate into existing systems and data portals with its gRPC-based ANYmal API to produce consistent inspection data and analysis reports. Work with a fleet of ANYmal X to easily scale your monitoring coverage and frequency.

ROBOT OPERATION

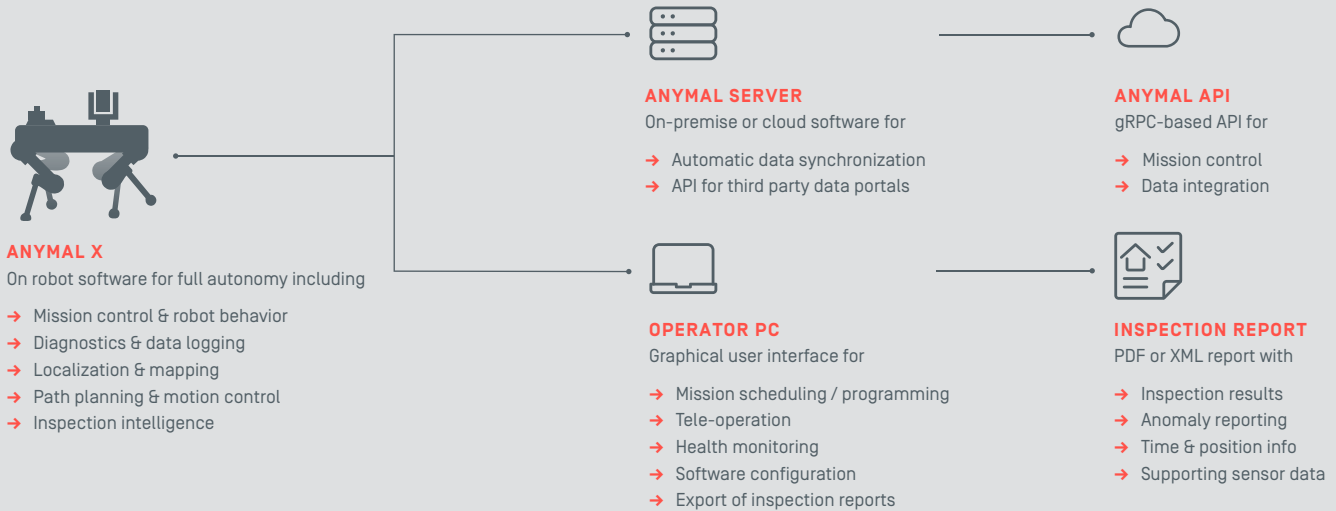

Charger

Charges the battery in the robot, outside the robot or automatically with the docking station in a safe zone.

Power supply 110–240 V / 50–60 Hz

Ingress protection IP65

Cable length 5 m (16.4 ft)

Dimensions 145 × 300 × 124 mm (L/W/H)
(5.71 × 11.81 × 4.88 in)

Weight 3.5 kg (7.72 lbs)

Docking station

Permits the robot to recharge itself after missions in a safe zone enabling fully autonomous operation. Extends the robot's mission range with deployment of additional docking stations along the route.

Ingress protection IP65

Required space for charging 1000 × 800 mm (L/W)
39.4 × 31.5 in

Dimensions 145 × 300 × 124 mm (L/W/H)
(5.71 × 11.81 × 4.88 in)

Weight 1.4 kg (3.1 lbs)



Operator Graphical User Interface

Plan and manage your robots from a single interface. The Operator GUI enables you to create, plan, and launch missions, operate the robot, visualize data from inspection events, and monitor the state and health of the robot.

The screenshot displays the ANYmal GUI interface. At the top, there are control buttons for 'AUTO' and 'MANUAL', along with status indicators for 'GUI: audr...', 'Surrounding', 'Communication', and 'Robot'. A central 3D visualization shows a robot in a factory setting with a 'ReactorGoal' marked. A mission panel on the left lists tasks from '1: Ur dock' to '18: Dock'. A 'Thermal Camera' window is open on the right. A red 'P-STOP' button is located in the top right corner. A status bar at the bottom indicates 'E-STOP'.

- 1 Mission panel**
Select and launch missions and observe mission progress.
- 2 Robot status bar**
Check critical information about the robot's status including localization and obstacles.
- 3 Protective stop button**
Easily accessible button to trigger a protective stop to bring the robot in a safe state.
- 4 3D visualization**
Plan and observe the robot's work environment including navigation & inspection goals, point clouds, and 3D models (if available).
- 5 Inspection window**
Select point of interest for inspection, record inspection results as pictures & videos, and set up inspection points for autonomous missions.
- 6 Sensor panel**
Stream and record sensor data from the onboard cameras and Lidar.

Data Integration and Compliance

ANYmal X offers seamless integration into your existing systems and workflows. Install your own software on the robot or connect ANYmal X securely to your cloud software. ANYmal X complies with IECEx, ATEX, ISO, and CE standards.

Data Integration

On server

API based on open-source Remote Procedure Call framework (gRPC) enables:

- Inspection results export to data portals, maintenance management systems, digital twins, or 3rd party data systems
- Mission triggering and status, including task progress
- Connection status and offline caching of inspection results

On robot

API based on open-source ROS (Robot Operating System) C++ plugins for inspection modules enables custom configuration and integration of custom payloads.



Data security & privacy

Enterprise WPA2 secured Wi-Fi is supported. Data file transmissions are encrypted by TLS 1.2 and live data transmissions are protected by VPN. Authorization is granted via TLS certificates.

Safety & Compliance

Ex certification

IECEx compliant Ex db eb ib op is pxb sb IIB T4 Gb
ATEX compliant  II 2G IIB T4

Emergency stop

Push button on the robot to disconnect complete power supply complies with ISO 13849-1:2015 Category 3 PL c.

Smart Device Protective Stop

Smart device application offers button to disable the actuators.

Compliance

CE marked complying with Machinery Directive 2006/42/EC (MD), EMC Directive 2014/30/EU (EMCD), Low Voltage Directive 2014/35/EU, Radio Equipment Directive 2014/53/EU (RED) and Restriction of Hazardous Substances in Electrical and Electronic Equipment (ROHS) 2011/65/EU.

Certification and compliance

ANYmal X is the only Ex-certified legged robot and it complies with the relevant ISO categories and CE directives for industrial deployment.



Getting Started

We partner with customers to define business goals and how ANYbotics can contribute to solving inspection tasks based on the requirements of their environment and applications. Based on our analysis, we provide a custom offer that covers your exact needs. Contact us to assess the application of autonomous inspection robots in your operations or ask for an on-site demonstration at your facility via anybotics.com or info@anybotics.com.



Use Cases

Learn more about ANYmal X's use cases and impact in the Oil & Gas and Chemicals industries.

anybotics.com/news/

Follow us

LinkedIn
YouTube

linkedin.com/company/anybotics
youtube.com/anybotics

ANYbotics AG
Hagenholzstrasse 83a
8050 Zürich

ANYbotics