A detailed view of the ANYmal robot, showing its red body, grey legs, and head with sensors. The robot is positioned on the left side of the page, facing right.

Generation D

ANYmal Technical Specifications

- Leading Autonomy & Mobility
- Intelligent Inspection
- Industrial Grade

ANYbotics



Leading Autonomy & Mobility

Complete autonomous navigation and AI-based mobility enable ANYmal to seamlessly conduct mission-critical inspections in multi-story and complex facilities with ease.

Intelligent Inspection

Utilizing high resolution sensors and cutting-edge machine learning, ANYmal delivers accurate real-time data, uploaded directly to customer systems via our ANYmal API.

Industrial Grade







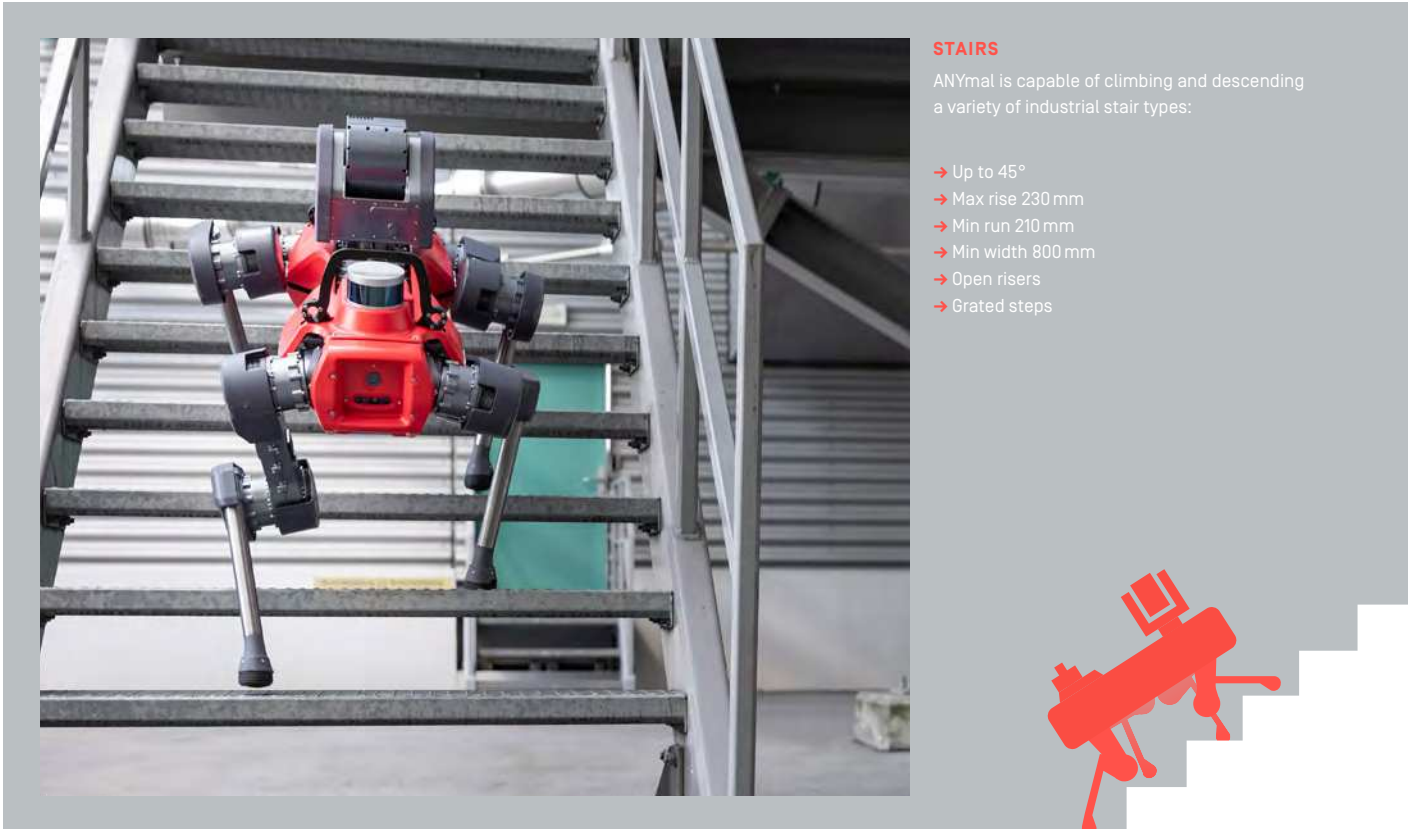

ANYmal is purpose-built for use in intricate industrial environments. Ruggedized design, impact protection, and IP67 dust and waterproofing make it well-suited to operating in harsh conditions.

Extreme Mobility

ANYmal's legged design and AI-based mobility software provide unprecedented mobility and performance. Combined with its obstacle avoidance capabilities, the robot is ready for use in complex and dynamic environments. The robot reliably navigates any environment and traverses rough terrain with ease. ANYmal completes even challenging missions requiring it to climb steep stairs, pass through narrow corridors, or conquer rocky, slippery, or wet surfaces.

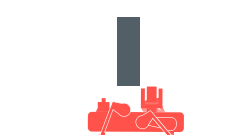

MOBILITY HIGHLIGHTS

<p>STEP 250 mm</p> 	<p>WALKING SPEED Up to 1.3 m/s, recommended 0.75 m/s for increased efficiency.</p> 	<p>NARROW SPACE 600 mm</p> 	<p>SLOPE ±30°</p> 
<p>ACCURATE POSITIONING Knows its absolute location with centimeter accuracy.</p> 	<p>GAP 300 mm</p> 	<p>SUSPENDED 600 mm</p> 	<p>OMNIDIRECTIONAL Steps sideways and turns in place.</p> 

Full Autonomy

ANYmal's unparalleled ability to perceive and navigate its environment powers fully autonomous operation. Once it maps an environment, the robot remembers every detail and can dynamically plan the best route to perform its mission, even without an internet connection. The robot's capabilities to avoid collisions, plan & re-plan paths, and recharge autonomously enable safe, efficient, and continuous autonomous operation.

ROBOT DEPLOYMENT

SHOW & GO

Show the robot the environment and tasks by manually guiding the robot through the plant and indicating the location of inspection points. Set up missions that the robot will remember and autonomously repeat.

IMPORT CAD / BIM

Import your existing CAD models to virtually set up inspection points, paths, and missions. Perform realistic simulations of your inspection missions and software integration before the robot arrives at your facility to save on deployment time.

NAVIGATION WAYPOINTS

ANYmal uses the points for autonomous navigation. It follows the shortest path between waypoints to target 3D coordinates throughout its inspection missions.

During deployment navigation waypoints are generated for planning robot missions. Points can later be added, edited, or removed in the Operator GUI.

INSPECTION POINTS & MISSION SETUP

Inspection points are defined as a special navigation goal for the robot in the user interface.

Inspection missions can be set up using the Mission Editor in the Operator GUI. Rule-based logic can be implemented to have the robot react to anomalies and alter its mission in real-time.

COLLISION AVOIDANCE MODES

The robot employs multiple modes to avoid collisions and safely stop near cliffs.

In *Stop & Go* the robot will stop before obstacles to avoid collisions and move again once the obstacle has moved.

In *Obstacle Avoidance* mode, if space is available, the robot will reroute around them. Alternatively, if a path is completely blocked, the robot can attempt to intelligently replan its route in order to complete its mission.

AUTOMATED CHARGING

The docking station enables continuous autonomous operation and is also defined as a point of interest during setup of the facility environment.

Missions can be set to any length as the robot will automatically navigate to the docking station when the battery is low and resume its mission after charging.

More information about the docking station and charger is available on page 8.

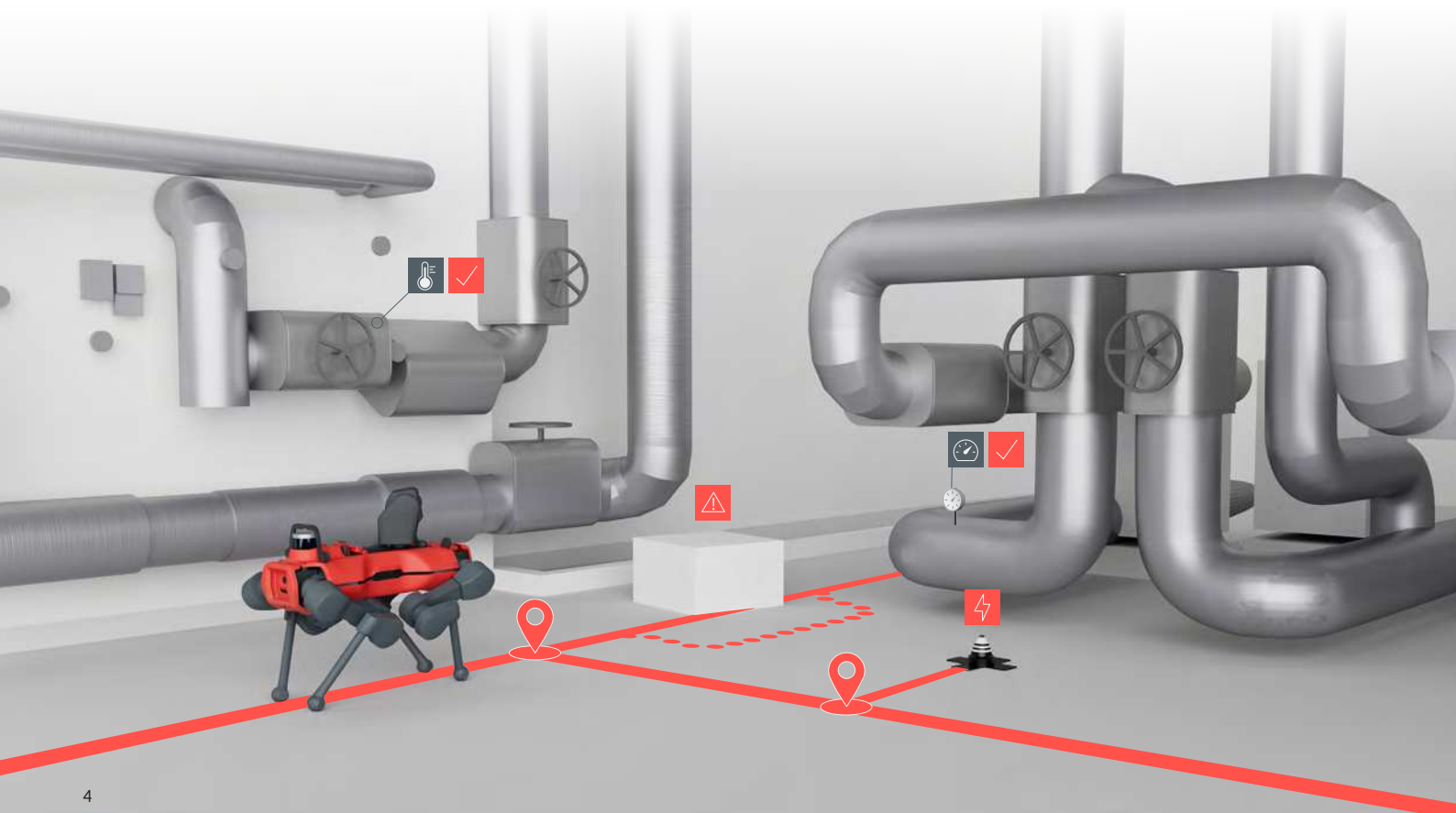

Industrial Inspection

READING INSTRUMENTS

A broad range of analog instruments and indicators can be digitized. Once trained on a type of instrument, the value or state is reliably identified.

Example: Pressure value, success status, confidence level and image of an analog gauge are recorded on the robot and transmitted to your data portal.



DETECTING EVENTS

Unforeseen technical events can result in hazardous situations. Equipped with precision sensors, ANYmal detects dangerous conditions in the environment and triggers a warning when required.

Example: The temperature of the hottest point in the thermal image of a motor together with the image are reported to the plant operator.

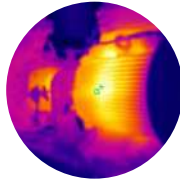

CHECKING HEALTH OF EQUIPMENT

Early signs of operating problems are caught by examining the general health of the equipment. During the inspection, ANYmal checks critical points for anomalies and reports severe problems immediately.

Example: Sound recording and frequency analysis to detect unusual vibrations is performed by ANYmal.



3D ENVIRONMENT SCANNING

Industrial environments require continuous tracking of structural changes. ANYmal supports operations by scanning and documenting 3d environmental data.

Example: Dense point clouds are recorded with the LiDAR and depth cameras of ANYmal and fused into a global point cloud map.



INSPECTION PIPELINE

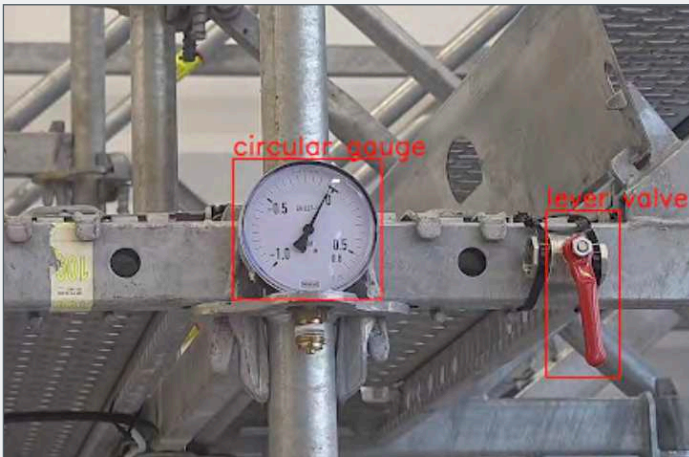

Detect and recognize objects, even if it has moved

Extract and process data

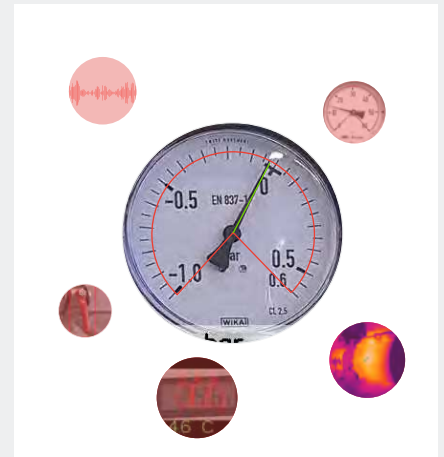

Collect multiple types of data for analysis and reporting

01



APPEND METADATA

Inspection results include pre-defined metadata fields such as time or location to add context to the data. The spatial metadata of each inspection point in your facility is recorded to ensure repeat inspection and support digital twins.

02



RULE-BASED LOGIC

Inspection missions can be programmed to change if certain inspection results are observed [e.g., a high or low threshold], enabling operators to prioritize inspection activities based on measured conditions on-site.

03



ASSOCIATE INSPECTION RESULTS

Multiple inspection results can be associated with each other to add additional context to the raw inspection data.

04



INSPECTION REPORTING

Generate reports of inspection results, export results to data portals or digital twin, or see inspection results live in the GUI when connected to the robot via Wi-Fi or LTE.

INSPECTION PAYLOAD

Zoom camera Default: 1080 × 1920 px (FullHD), 15 FPS
Maximum: 2160 × 3840 px (QFHD/4k), 30 FPS
20× optical zoom, 70.2° to 4.1° FOV (horizontal)

Thermal camera -40° to +550 °C (radiometry)
336 × 256 px
46° FOV (horizontal)

Ultrasonic microphone 0–384 kHz sampling frequency

Spotlight 1895 lm continuous, 3790 lm for short time

Range of motion Pan: ±165°, tilt: -90°/+180°
Speed: 340°/s

Dimensions 229 × 177 × 246 mm (L/W/H)
(9.02 × 6.97 × 9.69 in)

Weight 5.7 kg (12.6 lbs)



Inspection Payload Range of Motion

ANYmal's inspection payload captures visual, thermal, and acoustic data for generating insights about your equipment and infrastructure. The wide range of motion of the pan-tilt unit combined with highly accurate positioning and powerful sensors ensures accurate, reliable, and repeatable data collection even in low-light conditions.

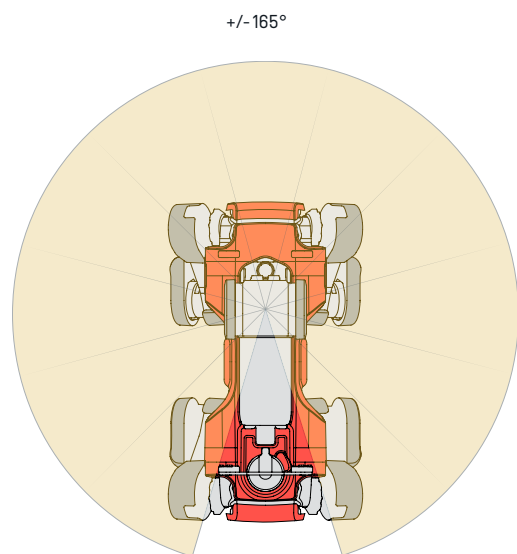
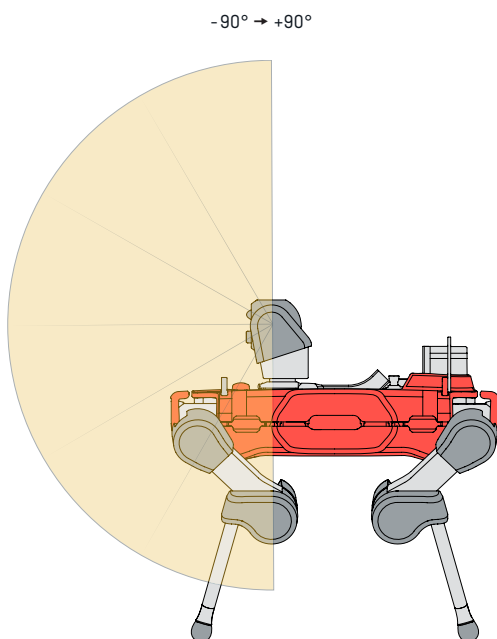

ANYmal

Dimensions	Length: 930 mm (36.61 in) Width: 530 mm (20.87 in) (default walking) Height: 890 mm (35.04 in) (default walking) / 470 mm (18.50 in) (lying on ground)
Weight	50 kg (110.2 lbs) / 55.7 kg (122.8 lbs) with Inspection Payload
Walking speed	1.3 m/s maximum, rough or slippery terrain may reduce the walking speed, 0.75 m/s recommended for safe and efficient operation

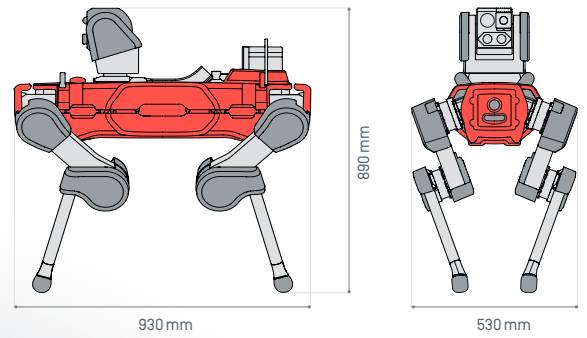

Edge Computing	
Computers	2x 8th Gen Intel Core™ i7 (6-core) CPU with 2x 8 GB Memory (RAM)
Hard disks	2x 240 GB SSD
Operating system	Ubuntu 20.04

Telecommunication	
Wi-Fi	Built-in module 2.4 / 5 GHz, 802.11ac wave2 Access point or client mode
4G LTE	Add-on module, LTE Cat.12

Battery	
Battery & capacity	Swappable Li-ion battery, UN 38.3 certified 932.4 Wh
Running time & range	90 – 120 minute on a full charge 4 km range on a full charge, up to 2 km for a typical inspection mission depending on payload weight and number of inspection points
Recharge time	3 h for full charge, 100 min for 70% quick charge
Dimensions	466 x 136 x 78 mm (18.35 x 5.35 x 3.07 in) [L/W/H]
Weight	5.5 kg (12.13 lbs)
Ingress protection	IP67

Perception Sensors	
LIDAR	16 channels, 300'000 points/s, full sweep at 10 Hz 0.4 – 100 m range, 3 cm accuracy (typical) 360 x 15.0 to -15.0° FOV (Horizontal x Vertical) 905 nm, Class 1 Eye-safe per IEC 60825-1:2007 & 2014
Depth camera	0.3 – 3 m range, 87.3 x 58.1 x 95.3° depth FOV (Horizontal/ Vertical/ Diagonal), Class 1 Laser Product under the EN/IEC 60825-1, Edition 3 [2014]
Tele-operation cameras	1440 x 1080 px 110 x 76.5 x 117.7° FOV (Horizontal/ Vertical/ Diagonal)

Environmental conditions	
Temperature	Specified: 0 – 40°C (32 – 104°F) Typical: -10 – 50°C (14 – 122°F)
Day & night	No light required for autonomous operation and inspection. Low light [min. 20 lux] needed for automatic docking and tele-operation.
Water & dust ingress protection	Fully protected against water and dust (IP67) and able to operate in humid and dusty conditions.
Industrial floor	ANYmal walks on metal, concrete, gratings / checkerboards, gravel, dirty, wet and slippery floors.

Perception Sensors Field of View

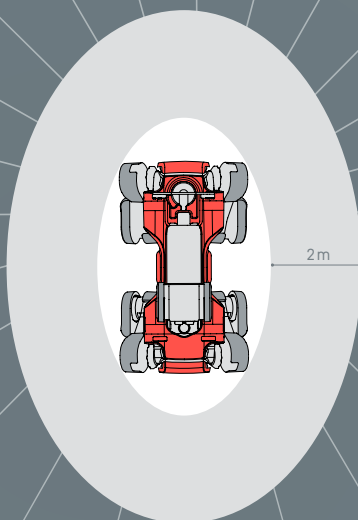

Dynamic sensing	
High density near field sensing	Nearby the robot, the depth cameras detect details about the environment and obstacles within 2 m.
Accurate long range sensing	The powerful onboard Lidar is used for mapping, localization, and collision avoidance up to 100 m.

100 m

2 m

Automated End-to-End Workflow

Pre-scheduled or upon your operator's request, ANYmal performs automated inspection routines with improved reliability and accuracy. The robot and its results integrate into existing systems and data portals with its gRPC-based ANYmal API to produce consistent inspection data and analysis reports. Work with a fleet of ANYmals to easily scale your monitoring coverage and frequency.

ROBOT OPERATION

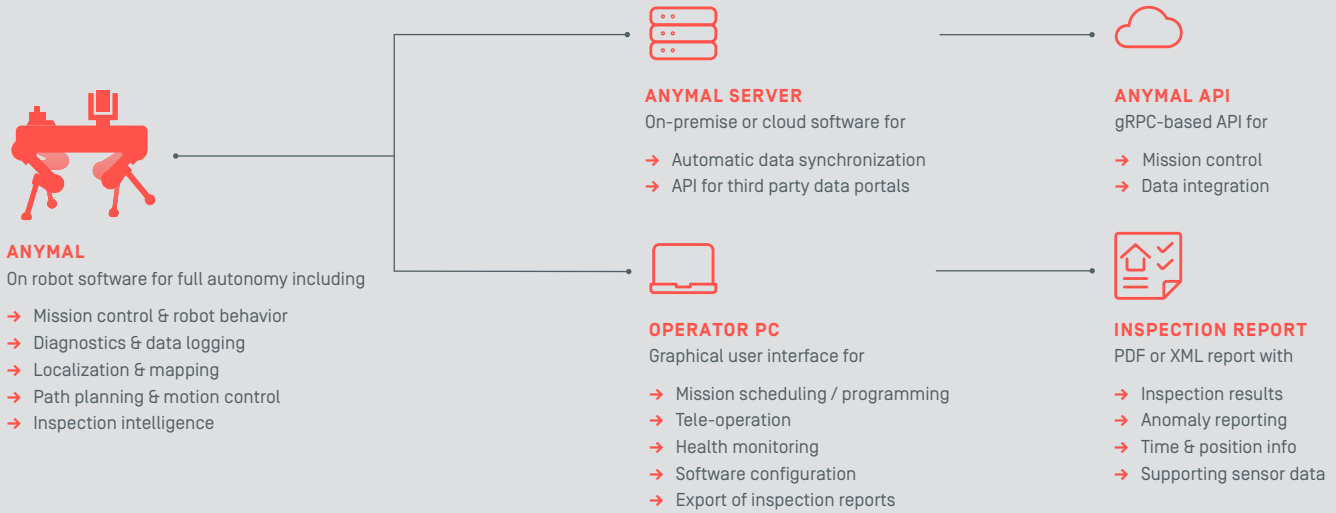

Charger

Charges the battery in the robot, outside the robot or automatically with the docking station.

Power supply 110–240 V / 50–60 Hz

Ingress protection IP65

Cable length 5 m (16.4 ft)

Dimensions 145 × 300 × 124 mm [L/W/H]
(5.71 × 11.81 × 4.88 in)

Weight 3.5 kg (7.72 lbs)

Docking station

Permits the robot to recharge itself after missions enabling fully autonomous operation. Extends the robot's mission range with deployment of additional docking stations along the route.

Ingress protection IP65

Required space for charging 1000 × 800 mm [L/W]
39.4 × 31.5 in

Dimensions 145 × 300 × 124 mm [L/W/H]
(5.71 × 11.81 × 4.88 in)

Weight 1.4 kg (3.1 lbs)



Operator Graphical User Interface

Plan and manage your robots from a single interface. The Operator GUI enables you to create, plan, and launch missions, operate the robot, visualize data from inspection events, and monitor the state and health of the robot.

1 Mission panel
Select and launch missions and observe mission progress.

2 Robot status bar
Check critical information about the robot's status including localization and obstacles.

3 Protective stop button
Easily accessible button to trigger a protective stop to bring the robot in a safe state.



4 3D visualization
Plan and observe the robot's work environment including navigation & inspection goals, point clouds, and 3D models (if available).

5 Inspection window
Select point of interest for inspection, record inspection results as pictures & videos, and set up inspection points for autonomous missions.

6 Sensor panel
Stream and record sensor data from the onboard cameras and Lidar.

Data Integration

ANYmal offers seamless integration into your existing systems and workflows. Install your own software on the robot, create custom payloads for your specific application, or connect ANYmal securely to your cloud software.

On server

API based on open-source Remote Procedure Call framework (gRPC) enables:

- Inspection results export to data portals, maintenance management systems, digital twins, or 3rd party data systems
- Mission triggering and status, including task progress
- Connection status

On robot

API based on open-source ROS (Robot Operating System) C++ plugins for inspection modules enables custom configuration and integration of custom payloads.



Data security & privacy

Enterprise WPA2 secured Wi-Fi is supported. Data file transmissions are encrypted by TLS 1.2 and live data transmissions are protected by VPN. Authorization is granted via TLS certificates.

Interface for Customization

	Interface on robot platform	Additional interface on inspection payload
Data link	USB link with Type-C connector M12 X-coded Ethernet link to onboard network Time sync trigger	RS232 RS485
Electrical power	Regulated 12VDC / 3 A Unregulated battery voltage (30.4 – 50.4 VDC) / 3 A	2× 12V / 1A
Mechanical interface	12× M4 screw holes	
Compute power	Custom software can be installed on the onboard computers. A plugin-based interface enables seamless integration of custom inspection software into mission control and inspection framework.	
Payload weight	Up to 10 kg (22 lbs) under nominal conditions, up to 15 kg (33 lbs) with reduced performance, e.g., walking speed and operating time.	



Safety & Compliance

Emergency stop	Push button on the robot to disconnect complete power supply complies with ISO 13849-1:2015 Category 3 PL c.
Remote control emergency stop	Push button on remote control to disable the actuators, complies with ISO 13849-1:2015 Category 3 PL c.
Compliance	CE marked complying with Machinery Directive 2006/42/EC (MD), EMC Directive 2014/30/EU (EMCD), Low Voltage Directive 2014/35/EU, Radio Equipment Directive 2014/53/EU (RED) and Restriction of Hazardous Substances in Electrical and Electronic Equipment (ROHS) 2011/65/EU.



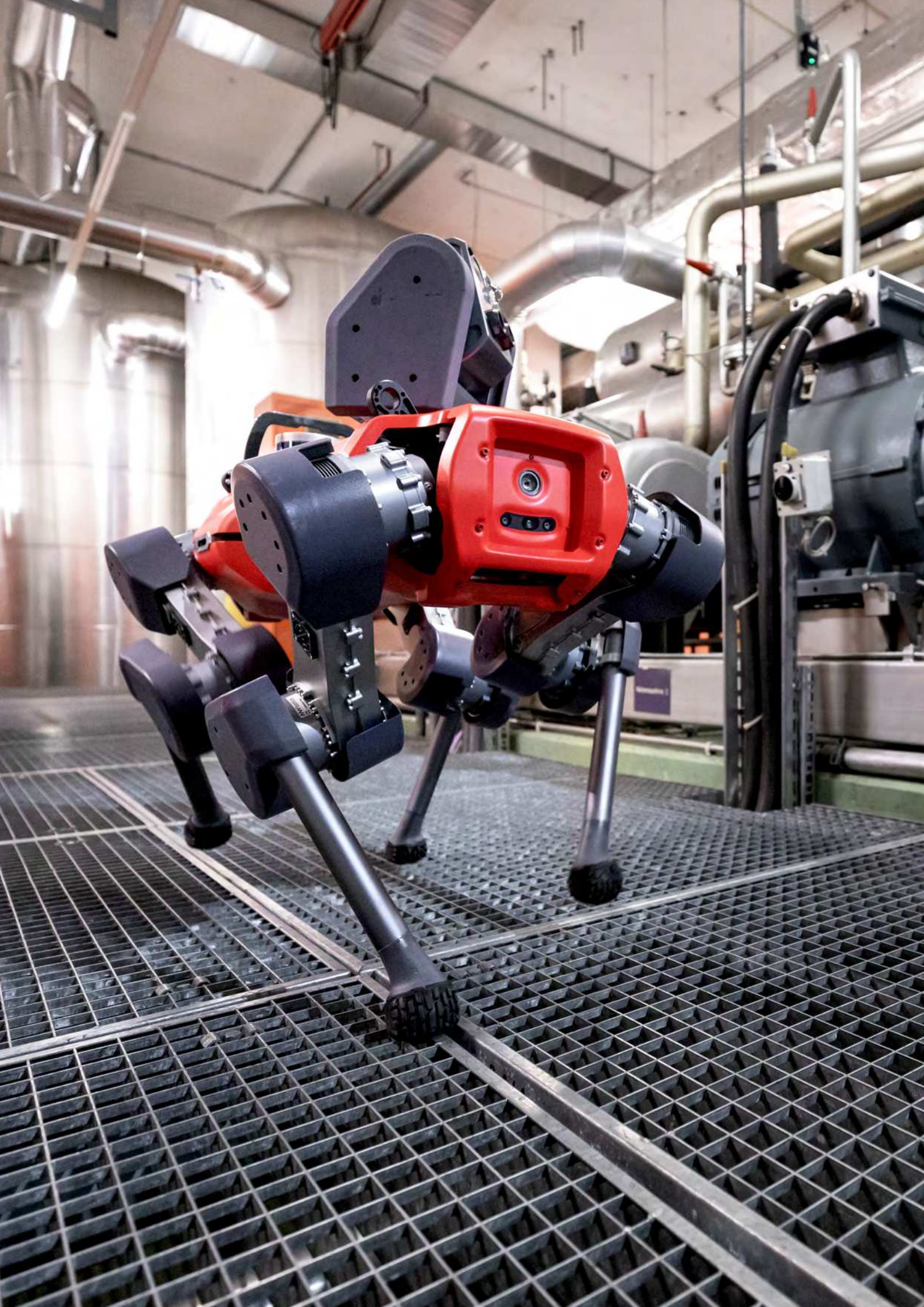

Getting Started

We partner with customers to define business goals and how ANYbotics can contribute to solving inspection tasks based on the requirements of their environment and applications. Based on our analysis, we provide a custom offer that covers your exact needs. Contact us to assess the application of autonomous inspection robots in your operations or ask for an on-site demonstration at your facility via anybotics.com or info@anybotics.com.



Use Cases

Learn more about ANYmal's use cases and impact in industries like Oil & Gas, Chemicals, Energy, or Mining:
anybotics.com/news/

Follow us

LinkedIn linkedin.com/company/anybotics
YouTube youtube.com/anybotics

ANYbotics AG
Hagenholzstrasse 83a
8050 Zürich

ANYbotics